

Series 1580 In-Line Mounted Centrifugal Fire Pumps

Installation, Operation & Service Instructions

INSTRUCTION SHEET

52X11747

LOCATION

If the pump is not installed on a closed system, it should be placed as near as possible to the source of supply, and located to permit installation with the fewest number of bends or elbows in the suction pipe.

The installation must be evaluated to determine that the Net Positive Suction Head Available (NPSHA) meets or exceeds the Net Positive Suction Required (NPSHR), as stated by the pump performance curve.

ALIGNMENT

The compact construction of this pump makes it very unlikely that any misalignment of parts will occur, but a check should be made before putting the pump in service by turning the shaft by hand to determine that there is no binding.

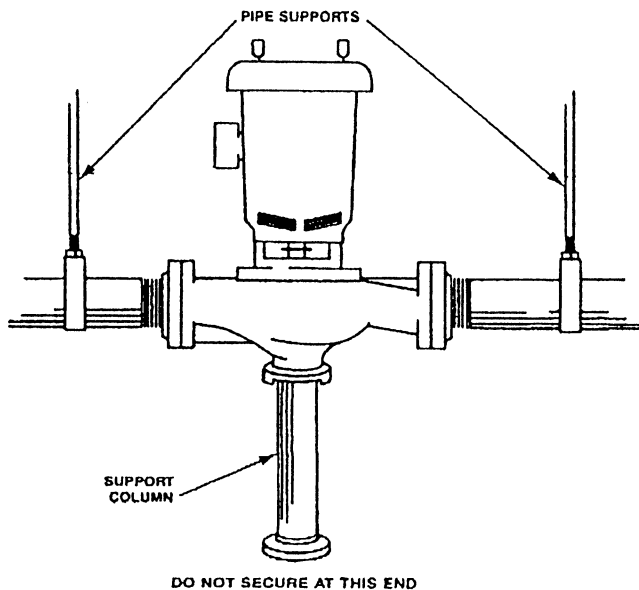

PIPING

It is important that air be kept out of the system. On an open system always place the end of the suction pipe at least 3 feet below the surface of the water in the suction well to prevent air from being drawn into the pump. Avoid air pockets in the suction line and make sure that each section of the suction pipe is absolutely air tight.

Install an isolating valve and check valve in the discharge pipe close to the pump. The check valve should be between the isolating valve and the pump discharge nozzle (in accordance with NFPA 20). The isolating valve can be used to shut off the discharge line while repairs are being made. The function of the check is to protect the pump casing from breakage that might occur due to the action of water hammer.

Be sure to eliminate any pipe strain on the pump. Support the suction and discharge lines by using pipe hangers or ground supports close to the pump. A support can be bolted to the underside of the pump body but it must be so constructed as to allow freedom of movement with the normal expansion of the piping.

If the pump is to be mounted in vertical piping with the motor in the horizontal position provide adequate support to prevent strain on pump parts and piping. It is not recommended that pump be mounted with the motor vertically downward. Do not use motor lift rings as a means of suspending the pump.

PRIMING

DO NOT RUN PUMP DRY. Before starting, these pumps must be filled with water. After the pump has been filled, turn the shaft a few times by hand to allow all air to escape and if necessary add more water.

LUBRICATION INSTRUCTIONS

All new ITT A-C Pump In-Line Mounted Centrifugal Fire Pumps are lubricated and test run at the factory; future lubrication should be in accordance with the motor manufacturer's instructions.

ROTATION

Rotation is clockwise when viewed from the top of the motor. An arrow cast into the pump body shows the direction of rotation.

SERVICE INSTRUCTIONS

1. Disconnect electricity to pump.
2. Close valves on suction and discharge sides of pump. (If no valves have been installed, it may be necessary to drain the system.)
3. Detach motor from pump volute by removing volute capscrews.
4. Remove impeller from motor shaft by turning impeller capscrew counterclockwise.

For Stuffing Box Construction — Packing

5. Remove flush tubing from stuffing box.
6. Remove the coverplate screws and pull entire assembly from the motor shaft with the packing intact.
7. The packing gland and packing can then be removed from the stuffing box.
8. Check the condition of the shaft sleeve and replace if scored or otherwise damaged.
9. Insert two new packing rings into the stuffing box followed by the lantern ring and two more pieces of packing. (Make certain that the packing joints are staggered 90 degrees.)
10. Install, but do not tighten, the packing gland.
11. Apply grease to the assembled packing and install over the motor shaft.
12. Assemble coverplate to bracket.
13. Finger tighten the packing gland until snug against first packing ring.

NOTE

The information contained on this sheet is intended to assist operating personnel by providing information on the characteristics of the purchased equipment.

It does not relieve the user of their responsibility of using accepted engineering practices in the installation, operation, and maintenance of this equipment.

Any further questions, contact ITT A-C Pump.
(513) 482-2500

14. Connect flush tubing to stuffing box and complete re-assembly by reversing removal instructions. **AFTER PUMP IS RUNNING AT FIRST START, WATER SHOULD RUN FREELY FROM PACKING.** Now the gland bolts can be tightened further, one half turn at a time so the tightening is uniform.

For fluid temperatures in the range of 30°F to 190°F, average leakage rates of 60 to 80 drops per minute are recommended. However, each individual pump and installation will have unique operating conditions that will result in broadly variable leakage rate requirements.

An adequate leakage rate is **NOT ONE SINGLE VALUE FOR ALL PUMPS AND INSTALLATIONS**, but is the amount required to provide adequate cooling and lubrication. The required leakage will be largely influenced by operating pressure, fluid temperature, shaft speed, etc.

At fluid operating temperatures near the upper limit of 190°F, the maximum temperature rise of the leakage is particularly important. A packed pump should never operate with steam forming at the gland. This necessarily limits the temperature rise to a maximum of about 20°F. If the formation of steam persists at higher leakage rates, cooling water must be provided by means of an external supply or a heat exchanger used to cool the by-pass flush.

If trouble occurs that cannot be rectified, contact your local ITT A-C Pump representative. We will need the following information in order to supply proper assistance.

1. Complete nameplate data of pump and motor.
2. Suction and discharge gauge readings
3. Ampere draw of the motor.
4. Voltage reading at motor.
5. A sketch of the pump hook-up and piping.